

Weatherproof manhole cover SD2, round type



The figure shown here may contain special accessories

Manhole cover, weatherproof, round in shape, completely made of 1.4307 (AISI 304 L) stainless steel.

In accordance with DIN 1239:2018-4, suitable for use in Ex zone 1.

The cover is made of 2 mm stainless steel plate, with a centrally raised profile, inner cross bracing for rigidity, self-retracting lock, stainless steel gas assisted spring damper, integrated arrestor which can only be undone by hand; robust, concealed hinges.

A connection for potential equalisation is provided.

The frame consists of an angle section with a circumferential insect-proof and totally weather-proof rubber seal (frost-proof and weather-resistant), with clips welded to the bottom side, designed for embedding in concrete, or for dowelling.

Manhole cover and frame shielded arc-welded, acid-treated in a pickling bath and passivated.

Operating key included.

Options:

- 1.4404 (AISI 316 L) stainless steel
- Air vent DN 150, centrally welded
- Insulation of the cover, without FCKW
- Fixing material and foam rubber gasket
- Safety lock for increased security, with or without profile cylinder
- Non-standard sizes
- Possibility to open the cover from below
- 4 mm cover plate
- Magnetic contact (cover open/shut indicator)
- Handle
- Pollen filter or biofilter (for odour elimination) or wind ventilator within the air vent
- Separable cover and frame
- Seal glued to the bottom side of the cover
- Lacquer according to RAL colour chart
- Surface made of tear pattern plate
- Fire-service standard lock, for pillar hydrant key DIN 3223, M 12 (supplied without key)
- Safety guard / antifall guard
- Multi-part cover

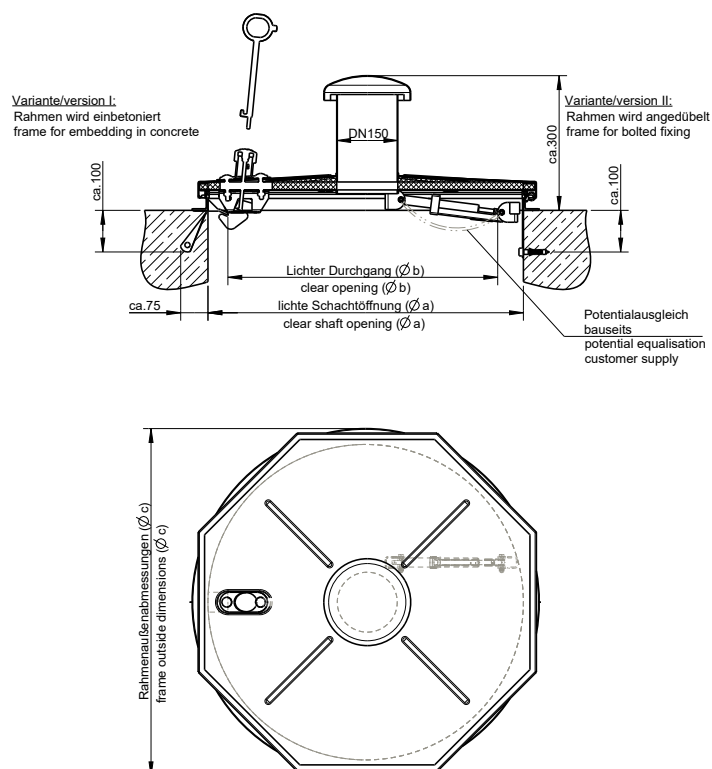

Model	Size $\varnothing a$	Order no.	Inside pass $\varnothing b$	Frame outside dimensions $\varnothing c$
Standard model	600	106/GR (1)	495	675
Standard model	800	108/GR	695	875
Standard model	1000	101/GR	895	1075
With air vent DN 150	600	106/GDR (1)	495	675
With air vent DN 150	800	108/GDR	695	875
With air vent DN 150	1000	101/GDR	895	1075
With insulation of cover, without FCKW	600	106/IR (1)	495	675
With insulation of cover, without FCKW	800	108/IR	695	875
With insulation of cover, without FCKW	1000	101/IR	895	1075
With air vent DN 150 and insulation of cover, without FCKW	600	106/IDR (1)	495	675
With air vent DN 150 and insulation of cover, without FCKW	800	108/IDR	695	875
With air vent DN 150 and insulation of cover, without FCKW	1000	101/IDR	895	1075

Ask for further dimensions. All measurements in mm.

(1) Note: According to German standards GUV-V C5 "Abwassertechnische Anlagen" and DVGW Arbeitsblatt W122 "Abschlußbauwerke für Brunnen der Wassergewinnung", the minimum clear width of entrance openings must be 0.8 m.

HUBER SE

Industriepark Erasbach A1 · D-92334 Berching
Phone: + 49 - 84 62 - 201 - 0 · Fax: + 49 - 84 62 - 201 - 810
info@huber.de · Internet: www.huber.de

Subject to technical modification
Drawing no. 50739517, 5.2022

Weatherproof manhole cover SD2, round type