

## ➤➤➤ Aeration/deaeration plant L661, max. throughput 3000 m<sup>3</sup>/h

**Natural aeration/deaeration plant** with air connections on both sides to improve the hygiene in drinking water reservoirs. Completely made of 1.4307 stainless steel except the filter material, shielded arc welded, acid-treated in a pickling bath and passivated.

### Comprising:

#### Item 1.0

**Security louvre**, attack-proof, pre-finished, rigid design, with a stable frame, slats and 1 x 1 mm insect screen. The insect screen serves as first filter stage and prevents the ingress of small animals, insects and organic coarse material. Minimum size: 1000 x 800 mm

Dimensions: W x H =

#### Item 2.0

**Air line** in partial lengths according to the specific local conditions, with a connecting plate designed to suit the louvre (item 1.0) for air-tight bolted fixing to the interior structure wall, with pipe connection piece. Pipeline DN \_\_\_\_\_, longitudinal welded seam stainless steel pipe, bends as required, flexible joints, including fixing material, foam rubber gasket and mounting brackets.

#### Item 3.0

**Air filter unit L661** with connection pieces on both sides, suitable for the air line, with pre-filter and filter for suspended matter, with two DN 15/2" stainless steel condensate drains upstream and downstream of the filter package, each with ball valve, including wall mounting brackets.

The air filter unit is designed for installation directly into the air line. The pre-filter installed in the air line is filter class ISO ePM10 75% according to EN ISO 16890 and serves as second filter stage. The pre-filter is required to increase the lifetime of the subsequent suspended material filter as third filter stage. This filter is filter class H13 with a separation rate of at least 99.99% in compliance with DIN EN 1822. Both filters consist of a germ-killing material that ensures the drinking water hygiene even under high loads and air moisture.

A pressure transducer controls filter pollution. The pressure is measured upstream and downstream of the filter pack, the pressure differential is shown as a four-digit display value and additionally as an analogue value 0 ... 10 V, 4 ... 20 mA.

Standard measuring range: 0 ... 1000 Pa, preset to 500 Pa

Supply voltage: 24 V AC/DC

Linearity: ±1,5%

Temperature drift: 0.1% per K

Cable screw connection: M 12

Protection grade: IP 65

Relay output: potential-free changeover contact

Connection to a telecontrol plant or alarm system is possible.

A connection for power must be available.

### Type L661

Air filter tank L x W x H = 720 x 640 x 725 mm.

#### Item 4.0

Safety valve as an additional overpressure/underpressure protection to protect the structure in case of operating troubles. The response pressure is 1000 Pa.

Note: Tank stability must be guaranteed under any usual and exceptional operating conditions. Only with sufficient dimensioning of the structure and all components the customer is permitted, on his own risk, to do without a safety valve after consultation of the stress analyst on the customer's own responsibility.

#### Item 5.0

Ready-to-operate installation, without brickwork, plastering works and chiselling work, without electrical work, without drain pipe, including instruction of the operating staff on site.

### Optional equipment and spare parts

#### Item 6.0

Pre-filter of filter class ISO ePM10 75% in compliance with EN ISO 16890

#### Item 6.1

Suspended material filter, filter class H13, separation efficiency 99.99% in compliance with DIN EN 1822, for type L661

#### Option:

- 1.4404 (AISI 316 L) stainless steel
- Radial pipe ventilator for installation in DN \_\_\_\_\_ air line, for forced ventilation
- With power supply unit for regulating the pressure transducer from 230 V to 24 V.

## Aeration/deaeration plant L661

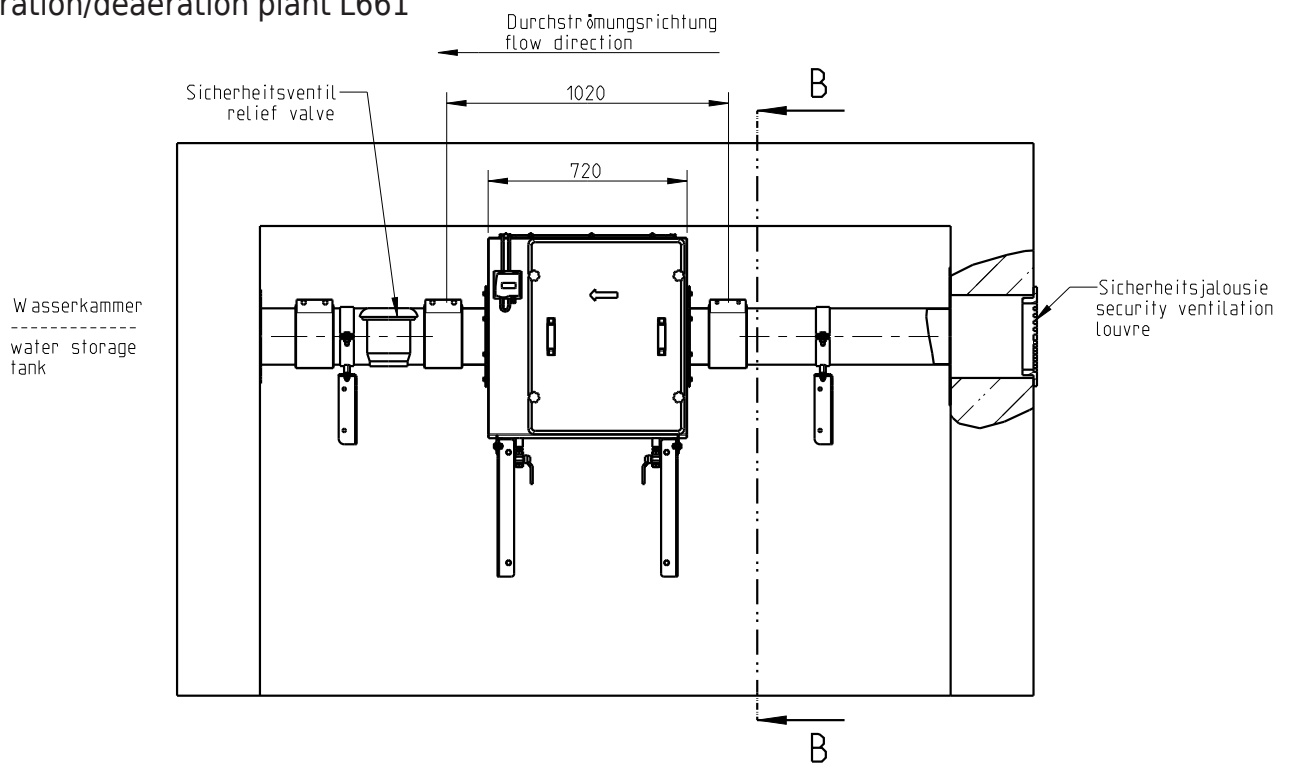

## HUBER SE

Industriepark Erasbach A1 · D-92334 Berching  
Phone: + 49 - 84 62 - 201 - 0 · Fax: + 49 - 84 62 - 201 - 810  
info@huber.de · Internet: www.huber.de

Subject to technical modification  
Drawing No. 190.114, 5.2022

Aeration/deaeration plant L661,  
max. throughput 3000 m<sup>3</sup>/h